



**EFFE 3 TI**

**ROTA X**

# Fully Automatic Rotary Arm Pallet Wrapping Machine

**Series S 5200**  
**S 5300**

Meets all CE Safety Norms **CE**

**EFFE 3 TI**

**PACKAGING TECHNOLOGIES**

HIGH REEFITY

**ROTAX**

## Automatic Rotary Arm Pallet Wrapping Machine

**Rotax wraps up your load in smooth style**

*2 year guarantee*

*Loaded with features*

*Low maintenance costs*

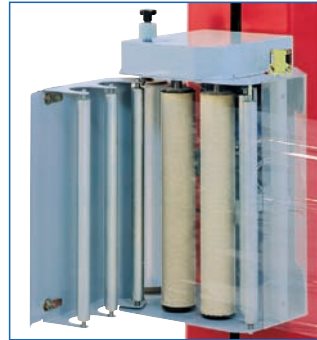

**MODEL 5300**  
Power pre-stretch up to 300%  
Rapid film reloading



**MODEL 5200**  
Adjustment of film tension through electromagnetic brake



S 5200

hine

## Standard technical features

Production capacity up to 50 pallets per hour  
Maximum pallet size: 1.200 x 1.200 x 2.300 (height) mm  
Speed of rotating arm adjustable up to 15 rpm from the control panel  
Speed of the film carrier adjustable from the control panel  
Power supply: 400 V 50 Hz



**ELECTRIC CABINET**

0 S 5300

# ROTAX

## MODEL 5200

### TECHNICAL FEATURES

Maximum pallet size 1.200 mm W x 1200 mm L x 2300 mm H  
 Minimum conveyor height 300 mm  
 Rotary arm supported on an oversize central ball bearing  
 Rotary arm rotation controlled by inverter  
 Adjustable film distributor speed controlled by inverter  
 Separated control cabinet  
 Digital display connected to a PLC  
 and the wrapping parameters to be preselected.

**Adjustment of film tension through electromagnetic brake**

## MODEL 5300

### TECHNICAL FEATURES

**Power Pre-stretch up to 300%**

# OPTIONAL

Top-press for light and unstable goods  
 Wrapping capacity up to 2800 mm  
 Safety fence around the machine H=2000  
 Safety light barriers with autodiagnostic

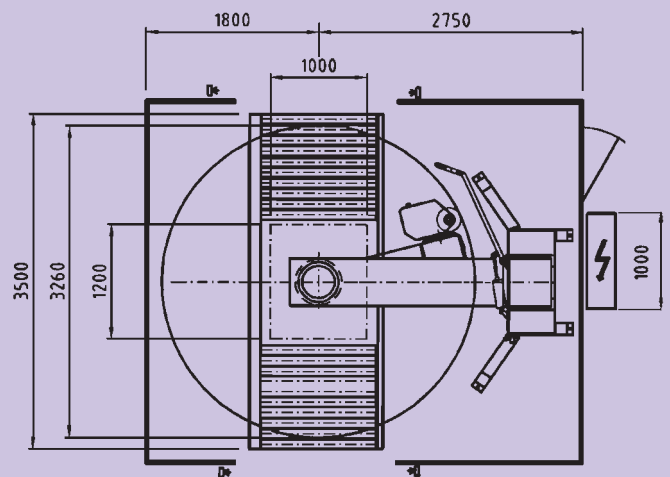
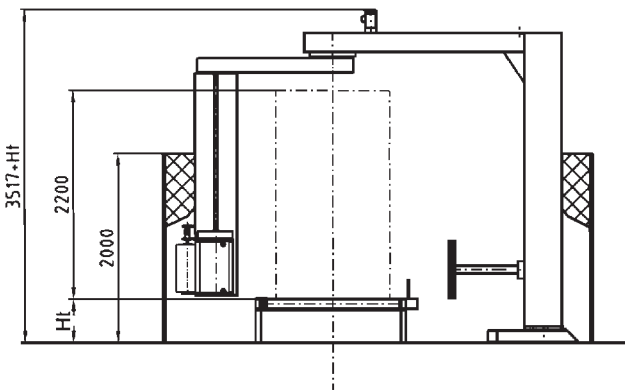

PACKAGING TECHNOLOGIES

C.so Garibaldi, 298 Gattinara 13045 (VC) ITALY - Tel. 0039 0163 828911 Fax 0039 0163 828990 - info@effe3ti.com www.effe3ti.com